



ACCU-SCOPE®

MANUAL

EXC-400
MICROSCOPE SERIES



CONTENTS

SAFETY NOTES 3

CARE AND MAINTENANCE 3

INTRODUCTION 4

UNPACKING AND COMPONENTS DIAGRAMS 4-6

ASSEMBLY DIAGRAM & PROCEDURE 7-11

ADJUSTMENT & OPERATION

 POWERING ON..... 12

 ILLUMINATION 12

 SPECIMEN SLIDE..... 12

 STAGE 12

 FOCUSING 13

 INTERPUPILLARY DISTANCE 14

 CONDENSER 14

 FIELD IRIS DIAPHRAGM..... 15

 APERTURE DIAPHRAGM..... 15

 LIGHT PATH..... 15

 FILTER..... 16

 OIL OBJECTIVE..... 16

 FUSE REPLACEMENT 17

 SIMPLE POLARIZER..... 17

 TURRET PHASE CONTRAST CONDENSER 18

 PHASE ANNULUS..... 18

 CAMERA ADAPTER..... 19

 TROUBLESHOOTING..... 20-22

 MAINTENANCE..... 23

 SERVICE..... 23

 WARRANTY 23

SAFETY NOTES

IMPORTANT NOTE – HOW TO CAREFULLY MOVE YOUR MICROSCOPE

When moving the microscope, always use both hands: place one hand in the back recessed hand grip area and the other under the front base and set the microscope down gently. Holding any other area of the microscope while moving (i.e., the stage, knobs, eyepieces or head), will cause damage to the microscope.

1. Open the shipping carton carefully to prevent any accessory, i.e. objectives or eyepieces, from dropping and being damaged.
2. Do not discard the molded foam container; the container should be retained should the microscope ever require reshipment.
3. Keep the instrument out of direct sunlight, high temperature or humidity, and dusty environments. Ensure the microscope is located on a smooth, level and firm surface.
4. If any specimen solutions or other liquids splash onto the stage, objective or any other component, disconnect the power cord immediately and wipe up the spillage. Otherwise, the instrument may be damaged.
5. All electrical connectors (power cord) should be inserted into an electrical surge suppressor to prevent damage due to voltage fluctuations.
6. For safety when replacing the LED bulb or fuse, be sure the main switch is off ("O"), remove the power cord, and replace the LED bulb after the bulb and the lamp house has completely cooled.
7. Confirm that the input voltage indicated on your microscope corresponds to your line voltage. The use of a different input voltage other than indicated will cause severe damage to the microscope.

CARE AND MAINTENANCE

1. Do not attempt to disassemble any component including eyepieces, objectives or focusing assembly.
2. Keep the instrument clean; remove dirt and debris regularly. Accumulated dirt on metal surfaces should be cleaned with a damp cloth. More persistent dirt should be removed using a mild soap solution. Do not use organic solvents for cleansing.
3. The outer surface of the optics should be inspected and cleaned periodically using an air stream from an air bulb. If dirt remains on the optical surface, use a soft cloth or cotton swab dampened with a lens cleaning solution (available at camera stores). All optical lenses should be swabbed using a circular motion. A small amount of absorbent cotton wound on the end of a tapered stick such as cotton swabs or Q-tips, makes a useful tool for cleaning recessed optical surfaces. Avoid using an excessive amount of solvents as this may cause problems with optical coatings or cemented optics or the flowing solvent may pick up grease making cleaning more difficult. Oil immersion objectives should be cleaned immediately after use by removing the oil with lens tissue or a clean, soft cloth.
4. Store the instrument in a cool, dry environment. Cover the microscope with the dust cover when not in use.
5. ACCU-SCOPE® microscopes are precision instruments which require periodic preventative maintenance to maintain proper performance and to compensate for normal wear. An annual schedule of preventative maintenance by qualified personnel is highly recommended. Your authorized ACCU-SCOPE® distributor can arrange for this service.

INTRODUCTION

Congratulations on the purchase of your new ACCU-SCOPE[®] microscope. ACCU-SCOPE[®] microscopes are engineered and manufactured to the highest quality standards. Your microscope will last a lifetime if used and maintained properly. ACCU-SCOPE[®] microscopes are carefully assembled, inspected and tested by our staff of trained technicians in our New York facility. Careful quality control procedures ensure each microscope is of the highest quality prior to shipment.

UNPACKING AND COMPONENTS

Your microscope arrived packed in a molded Styrofoam container. ***Do not discard the container:*** the Styrofoam container should be retained for reshipment of your microscope if needed. Avoid placing the microscope in dusty surroundings or in high temperature or humid areas as mold and mildew will form. Carefully remove the microscope from the Styrofoam container by the recessed hand grip area on the back of the microscope and base, and place the microscope on a flat, vibration-free surface.

COMPONENTS DIAGRAM

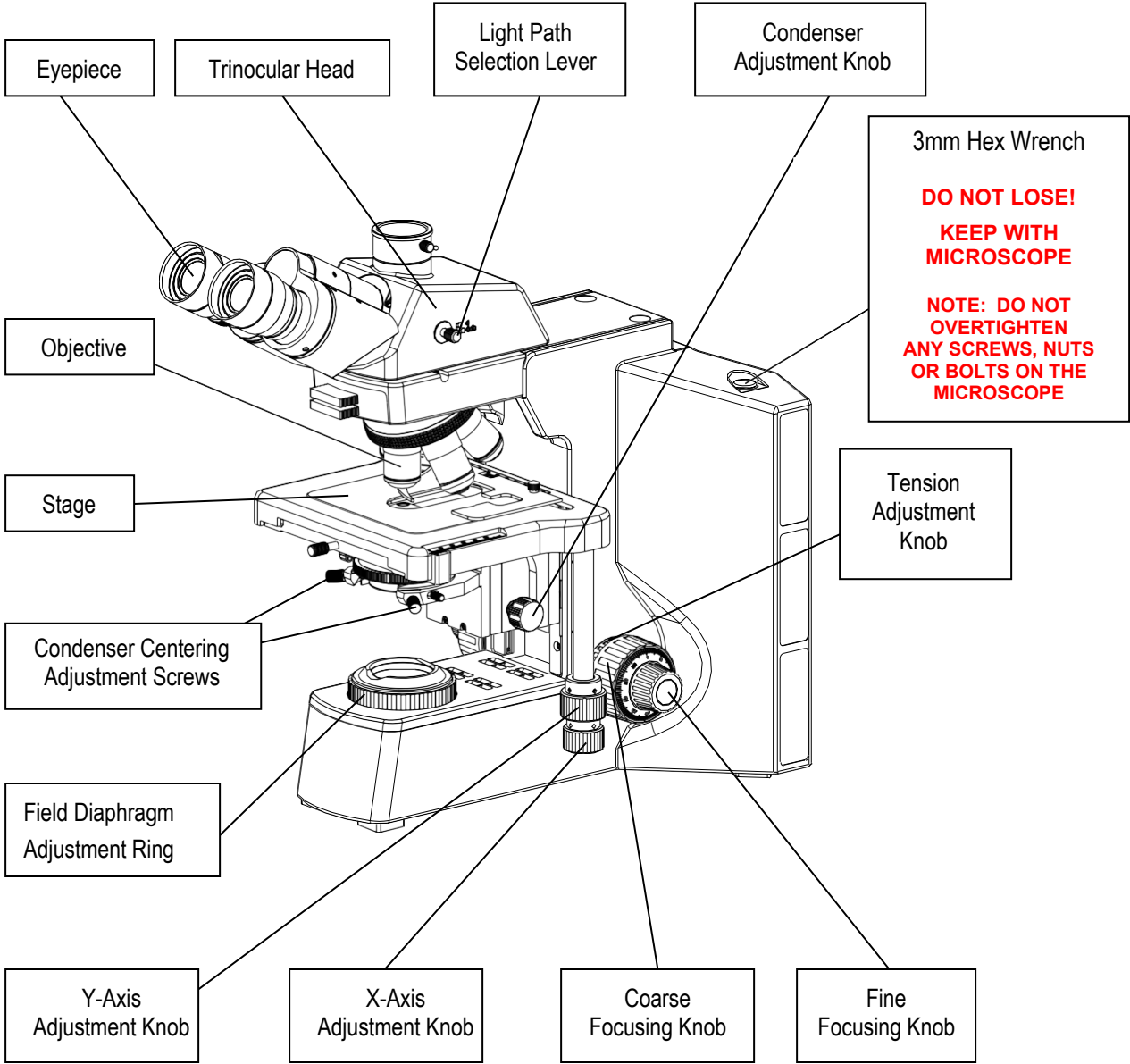

COMPONENTS DIAGRAM

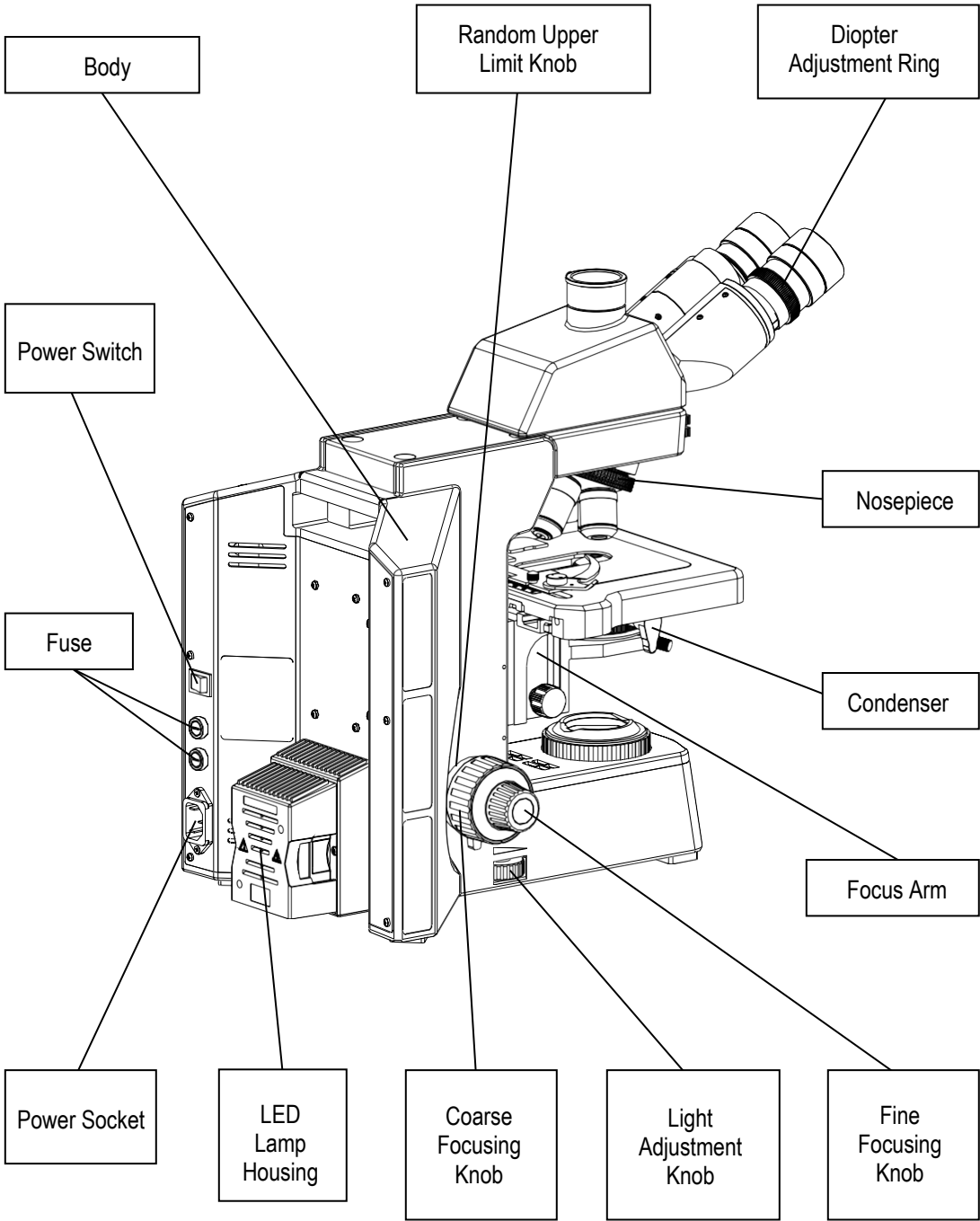

ASSEMBLY DIAGRAM

The diagram below shows how to assemble the various modules. The numbers indicate the order of assembly. Your microscope was preassembled by our factory technicians at our New York facility prior to shipment. Should you need to disassemble/assemble your microscope in the future, please follow the instructions outlined below.

When assembling the microscope, make sure that all parts are free of dust and dirt, and avoid scratching any parts or touching glass surfaces.

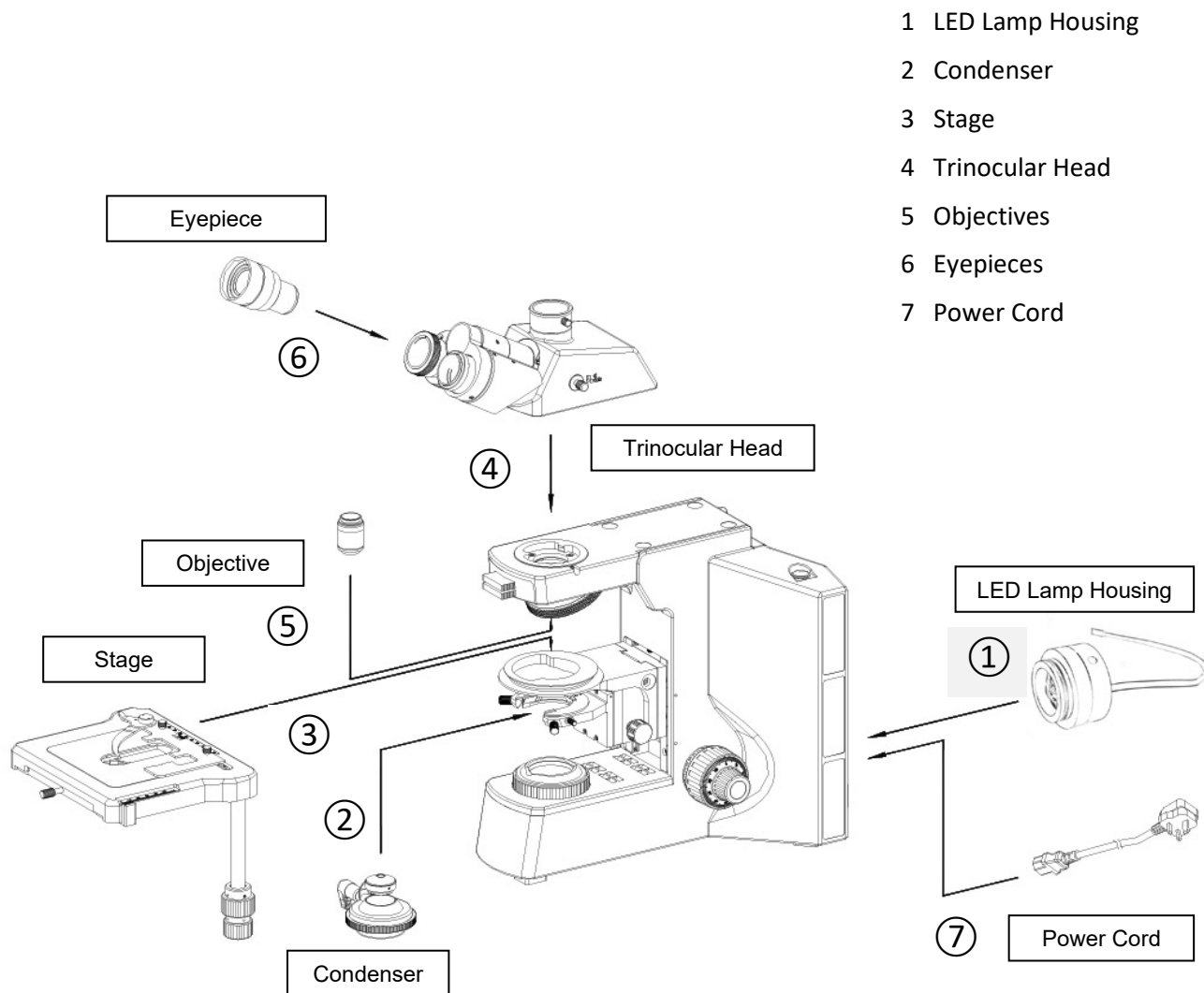

- 1 LED Lamp Housing
- 2 Condenser
- 3 Stage
- 4 Trinocular Head
- 5 Objectives
- 6 Eyepieces
- 7 Power Cord

DETAILED ASSEMBLY

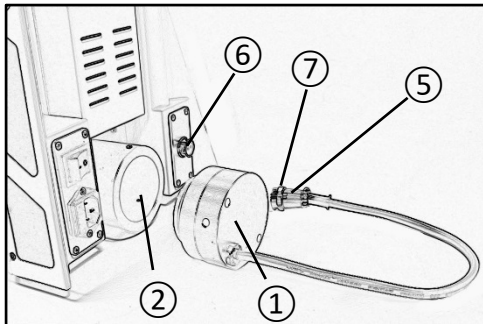

Fig. 1

Installing the LED Lamp Housing – Fig. 1 & 2

The LED lamp housing may come pre-installed. If it does not, follow these installation instructions:

Align the LED lamp housing (1) with the lamp facing toward the back of the microscope as shown (Fig. 1).

Gently slide the lamp housing onto the lamp housing receptacle (2) and tighten the set screw (3) with the included Hex wrench (4) (Fig. 2).

Align the pins in the end of the lamp housing power cord plug (5) with the lamp housing power cord socket (6) on the back of the microscope and slide the plug until it clicks into place (Fig 1).

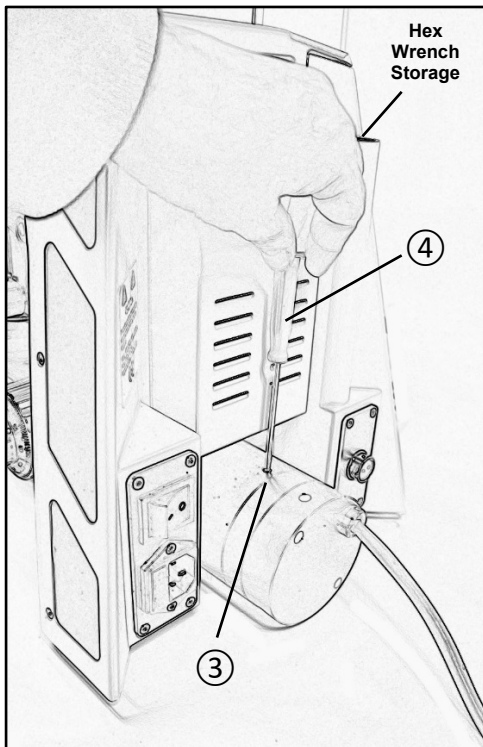

Fig. 2

NOTE: To unplug the lamp housing, turn the knurled ring (7) of the lamp housing power cord plug counterclockwise and slide it out.

DETAILED ASSEMBLY *(continued)*

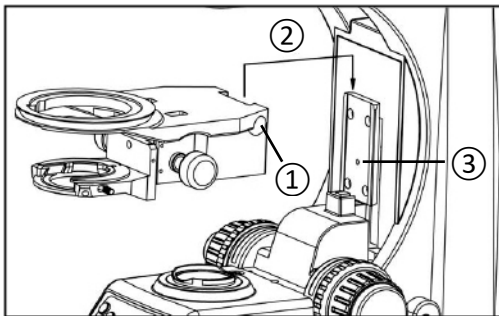

Fig. 3

Installing the Condenser/ Stage Carrier - (Fig. 3)

Using the 5mm Hex wrench that was provided with your microscope, loosen the lock screw (1).

Gently slide the dovetail of the condenser/stage carrier onto the dovetail slide mount (2) as shown until it sits firmly on the resting bolt (3).

Retighten the lock screw with the Hex wrench.

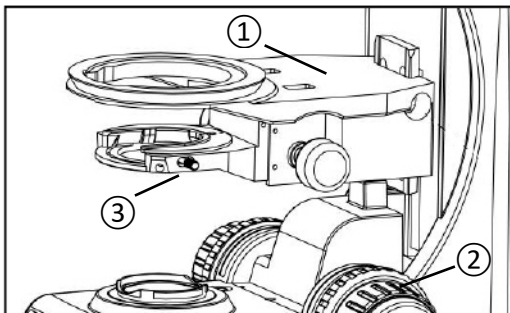

Fig. 4

Installing the Condenser - (Fig. 4 & 5)

Lower the condenser/stage carrier (1) to its lowest position by turning the coarse focusing knob counterclockwise (2).

Loosen the condenser thumb screw (3) by turning it counterclockwise.

Swing out the top lens of the condenser (4).

With the condenser scale facing you, align the condenser with the groove on the condenser carrier and carefully slide the condenser all the way into the carrier – if installed properly in the groove, you will feel it “snap” into place.

Gently retighten the thumb screw (3) by turning it clockwise.

NOTE: keep the condenser/stage carrier at its lowest position for installing the stage next.

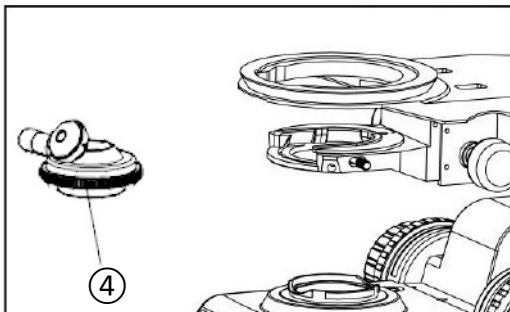

Fig. 5

DETAILED ASSEMBLY *(continued)*

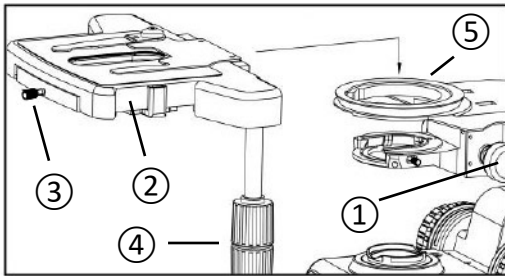

Fig. 6

Installing the Stage - (Fig. 6 & 7)

Lower the condenser to its lowest position by turning the condenser carrier knob counterclockwise (1).

Remove protective tape and bag from stage and specimen holder (2). (The stage comes with the specimen holder pre-mounted to the top of the stage).

Loosen the thumb screw (3) on the front of the stage.

Position the X-Y movement knobs (4) to the right and align the circular mount on the bottom of the stage with the circular bracket (5) on the condenser/stage carrier and set the stage in place so that it is centered over the condenser below.

Tighten the thumb screw (3) on the front of the stage.

Raise the condenser carrier by turning the knob clockwise.

Figure 7 shows the stage in place.

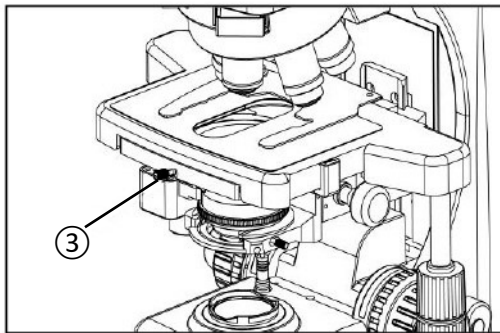

Fig. 7

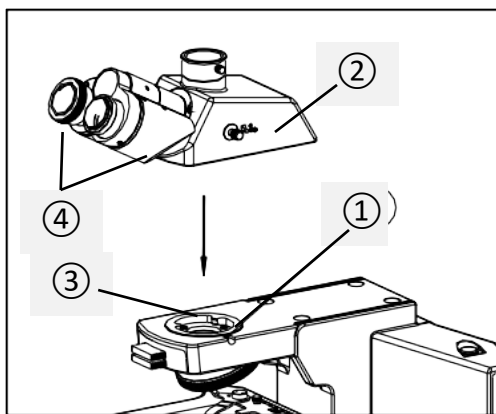

Fig. 8

Installing the Viewing Head - (Fig. 8)

Using the 5mm Hex wrench, loosen the lock screw (1).

Position the viewing head (2) above the dovetail opening (3) as shown and with it tilted slightly down on the right, slide the dovetail under the notches in the dovetail hole and set it into place with the two eyepiece tubes (4) facing forward.

Retighten the lock screw (1).

DETAILED ASSEMBLY *(continued)*

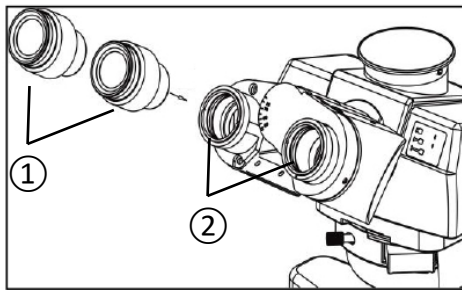

Fig. 9

Installing the Eyepieces - (Fig. 9)

Carefully remove the eyepieces ① from the protective packaging – be sure not to touch any optical (glass) surfaces. Remove the dust caps.

Insert an eyepiece ① into one of the eyepiece tubes ② and gently twist and push the eyepiece in until it is flush with the top surface of the eyepiece tube.

Repeat above for the other eyepiece.

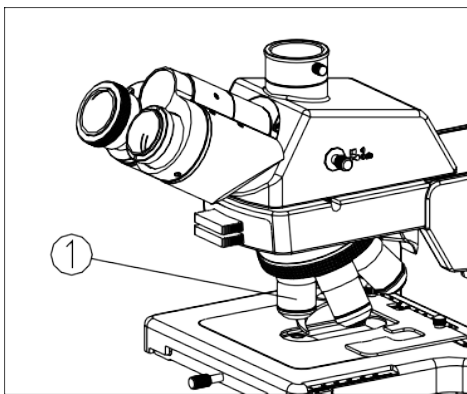

Fig. 10

Installing the Objectives - (Fig. 10)

Rotate the coarse focusing knob to lower the stage to its lowest position.

Install the objectives into the nosepiece ① from the lowest magnification to the highest in a clockwise direction beginning with the first empty objective receptacle in front.

Install each objective by using two hands to position and gently screw in the objective in a clockwise direction into the threads of the nosepiece receptacle.

NOTE: Never force any objectives onto the threads of the nosepiece, and do not over-tighten.

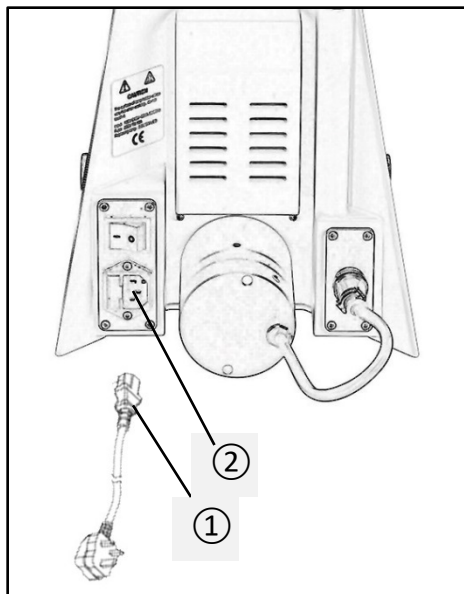

Fig. 11

Installing the Power Cord - (Fig. 11)

Align and plug the female end ① of the power cord into the power cord socket ② on the back of the microscope.

Plug the other end into a grounded (3-prong) outlet.

NOTE: Always use the power cord that is provided with your microscope; using a different power cord may damage your microscope. Should you need a replacement, contact your authorized ACCU-SCOPE dealer or call ACCU-SCOPE at 1-631-864-1000 for a dealer nearest you.

ADJUSTMENT & OPERATION

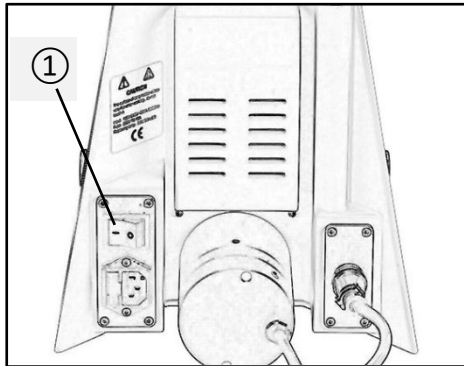

Fig. 12

Powering On - (Fig. 12)

With the microscope plugged in, locate and push the I/O toggle button ① on the back of the microscope to the ON (I) position.

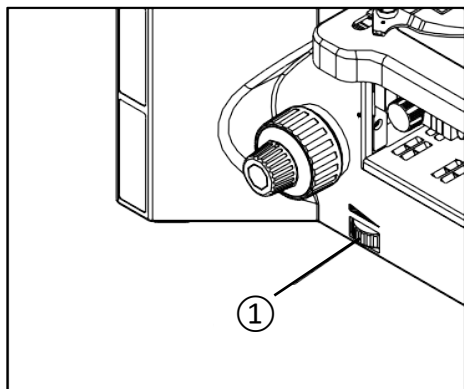

Fig. 13

Adjusting Brightness - (Fig. 13)

Adjust the Light Adjustment Knob ① until the illumination is comfortable for observation. Rotate the light adjustment knob clockwise (towards the back of the microscope) to increase the brightness. Rotate the light adjustment knob ① counterclockwise (towards the front of the microscope) to decrease the brightness.

Placing a Specimen - (Fig. 14)

Push the left side of the Specimen Holder ① on the top of the stage plate to open the holder.

Place your slide ② in and slowly release the holder to allow it to close firmly against the slide.

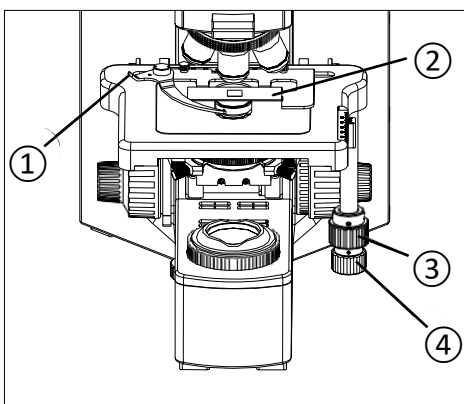

Fig. 14

Adjusting the Stage - (Fig. 14)

The stage has a coaxial X-Y Stage Movement Knob which allows you to move your specimen in any direction:

Top Knob ③: (Y) forward/backward movement

Bottom Knob ④: (X) left/right movement

ADJUSTMENT & OPERATION *(continued)*

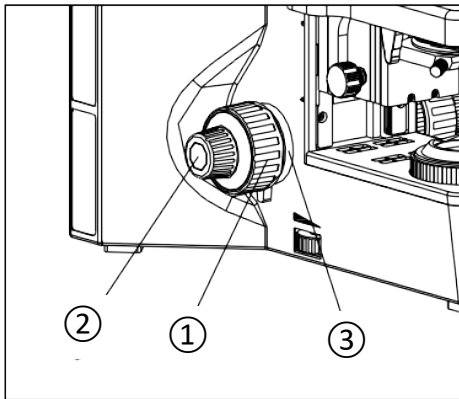

Fig. 15

Adjusting the Focus - (Fig. 15)

To ensure that you obtain sharp images with both eyes (since eyes vary, especially for those wearing glasses) any eyesight variation can be corrected in the following manner: set both diopter collars to "0". Using your left eye only and the 10X objective, focus your specimen by adjusting the coarse adjustment knob ①. When the image is in view, refine the image to its sharpest focus by turning the fine adjustment knob ②. Rotate the diopter collar to obtain the sharpest focus. To obtain the same sharp image using your right eye, do not touch the coarse or fine adjustments. Instead, rotate the right diopter collar until the sharpest image appears. Repeat several times to check.

NOTE: do not counter rotate the focusing knob as this will cause severe problems and damage to the focusing system.

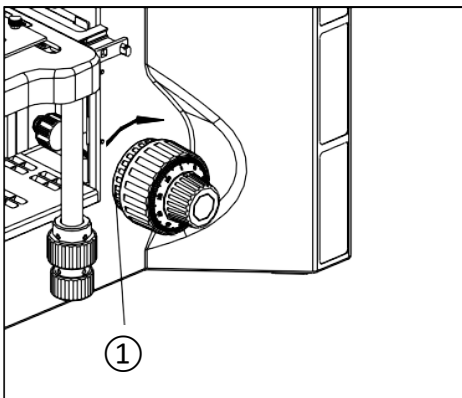

Fig. 16

Adjusting the Focus Stop - (Fig. 15)

Once you have adjusted the focus, turn the focus stop ③ clockwise to set your objective levels to a stop position so they will not come into contact with your slide.

Adjusting the Focusing Tension - (Fig. 16)

If the coarse focusing knob is very heavy when focusing or the specimen leaves the focus plane after focusing or the stage lowers by itself, please adjust the tension adjustment ring ①. Located on the left side of the stand between the coarse focusing knob and the vertical arm is an adjustable tension control dial that is preset at our facility. This allows the user to adjust the coarse control tension to their individual preference.

ADJUSTMENT & OPERATION *(continued)*

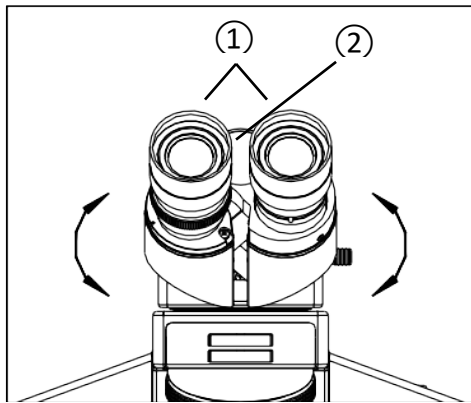

Fig. 17

Adjusting the Interpupillary Distance - (Fig. 17 & 18)

To adjust the interpupillary distance, hold the left and right eyetubes while observing a specimen. Rotate the eyetubes around the central axis until the fields of view of both eyetubes ① coincide completely. A complete circle should be seen in the viewing field when viewing the specimen slide. An improper adjustment will cause operator fatigue and will disrupt the objective parfocality.

Where “•” on the eyepiece tube lines up to the interpupillary scale ②, then that is the number for the interpupillary distance. Range: 50~76mm.

Remember your interpupillary number for future operation.

NOTE: The eyepiece tubes can be rotated 180° to increase the eyepoint height by 34mm to accommodate the needs of different users. (Fig. 18)

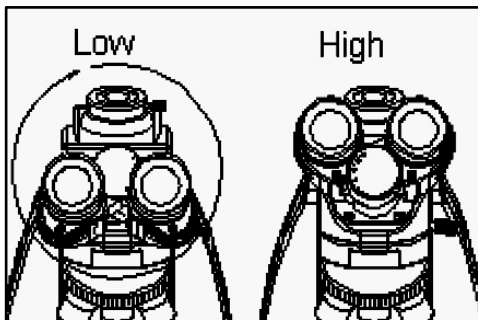

Fig. 18

Centering the Condenser - (Fig. 19 & 20)

Rotate the condenser knob ① to raise it to the highest position (Fig. 19).

Rotate the 10x objective into the light path and focus the specimen.

Rotate the field iris diaphragm adjustment ring ③ to put the field iris diaphragm to the smallest position.

Rotate the condenser knob and adjust the image to be its sharpest.

Adjust the center adjustment screws ④ and move the bright region to the center of the field of view (Fig. 20).

Open the field iris diaphragm gradually. If the image is in the center all the time and inscribed to the field of view, the condenser has been centered correctly.

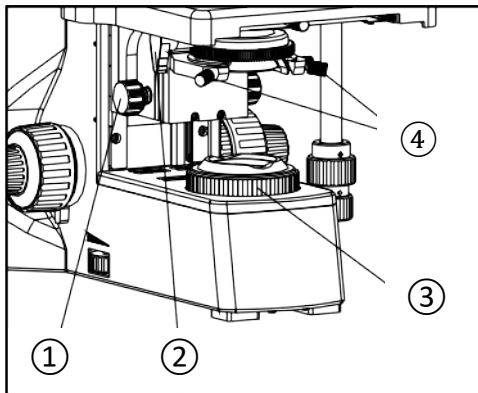

Fig. 19

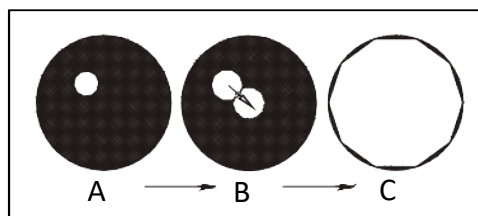

Fig. 20

ADJUSTMENT & OPERATION *(continued)*

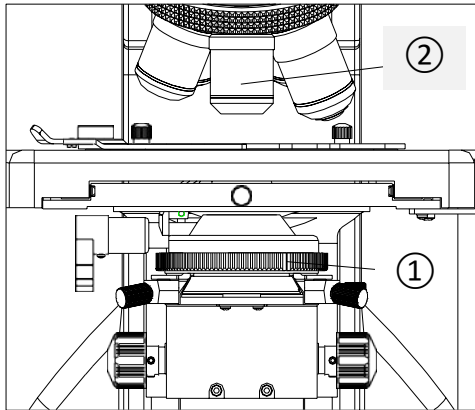

Fig. 21

Adjusting the Field Iris Diaphragm – (Fig. 20, C)

By limiting the diameter of the light entering the condenser, the field iris diaphragm can prevent other light and strengthen the image contrast. When the image of the diaphragm is just on the edge of the field of view, the objective can show the best performance and obtain the clearest image

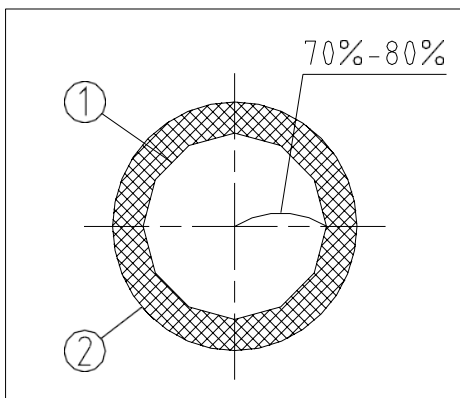

Fig. 22

Adjusting the Aperture Diaphragm – (Fig. 21 & 22)

The aperture size is increased or decreased by rotating the condenser aperture diaphragm ring ① (Fig. 21). When the aperture is closed, the brightness and resolution are decreased but the contrast and range of focus are increased. If the aperture diaphragm is opened, the brightness and resolution are increased; however, the contrast and range of focus are diminished. For optimal viewing conditions set the condenser aperture diaphragm lever to match the magnification of the objective ② in the optical path.

To confirm or as an alternative approach to adjusting the aperture diaphragm position, remove one eyepiece and look down the eyetube. The image will appear as in Fig. 22. Adjust the aperture diaphragm until it is approximately 70%-80% open. Replace the eyepiece and continue with observation. The aperture diaphragm position is different for each objective, so it is important to repeat the adjustment procedure every time the objective is changed.

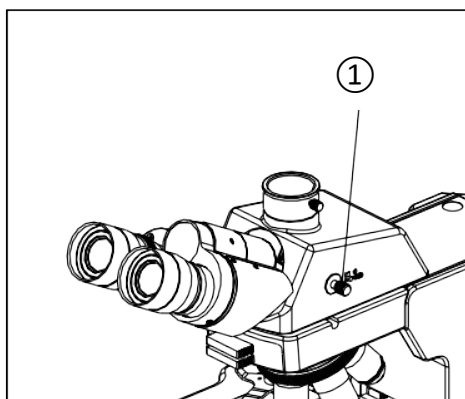

Fig. 23

Adjusting The Light Path - (Fig. 23)

The camera port on the trinocular viewing head allows you to view 100% through the eyepieces, or 50/50% to eyepiece/camera port.

To adjust the light path, push the Light Path Selector Knob ① all the way in to observe 100% through the eyepieces, or all the way out to observe through the eyepieces and the camera port (50% / 50%)

ADJUSTMENT & OPERATION *(continued)*

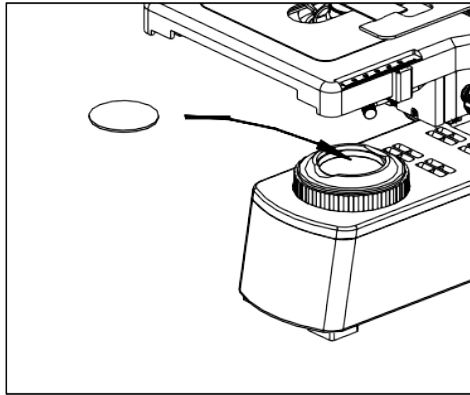

Fig. 24

Using & Installing A Filter – (Fig. 24)

A filter is used to make the background color more suitable for the application and as a method to increase the contrast.

Filters are available in LBD, yellow, green and ND filters.

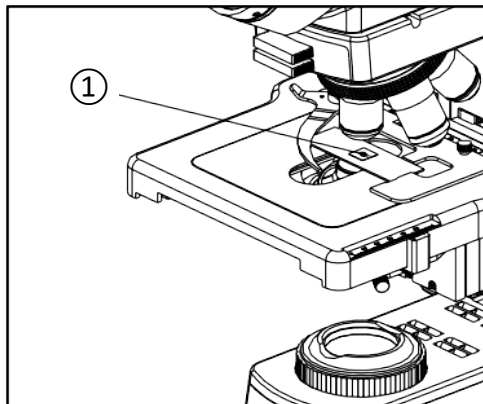

Fig. 25

Using An Oil Objective – (Fig. 25)

The procedure for examining a specimen using an oil immersion objective is as follows:

Rotate the nosepiece so the low power objective is in the optical path.

Place one drop of immersion oil on the lighted area of the specimen slide ①. Dust or air bubbles in the oil can destroy the definition of the image. If the bubbles are trapped between the objective lens and the slide, clean off the oil and start again or try to eliminate the bubble by rotating the objective back and forth.

Rotate the nosepiece so the 100xR oil immersion (or 50xR oil immersion) objective is in the light path.

With your eye at the level of the stage, use the coarse focus knob to raise the stage with the specimen cover glass. When you see a flash of light at this location the objective lens has made contact with the immersion oil and the microscope can now be focused using the fine focus knob.

IMPORTANT: Each time you finish using the oil immersion objective wipe off all traces of oil from the objective and the specimen cover glass with a lens tissue or clean soft cloth. Cleaning after each use will prevent oil from contaminating the high dry objective (40xR) and degrading its optical performance, prevent dust and dirt from accumulating on the lens of the objective and degrading its optical performance, and will keep the slide clean to work with.

ADJUSTMENT & OPERATION *(continued)*

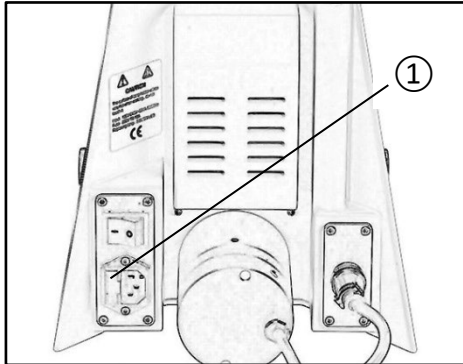

Fig. 26

Replacing the Fuse – (Fig. 26)

To replace the fuse, turn the main switch to “O” (OFF) before replacing the fuse. Unplug the power cord from the back of the microscope – this will allow you to access the tab on the fuse holder.

To make it easier to remove the fuse holder ①, remove the lamp housing by loosening the lock screw with the Hex wrench that is supplied with your microscope (see page 5).

Once the illuminator is removed, insert a flat (—) head screwdriver behind the tab on the fuse holder and pull toward you until the fuse holder “pops” out.

Replace the fuse with a 3.15 amp fuse (CAT# 350-3277-3), then slide the fuse holder back into place.

Reinstall the lamp housing (see page 7) and then reinstall the power cord into the power cord receptacle on the back of the microscope.

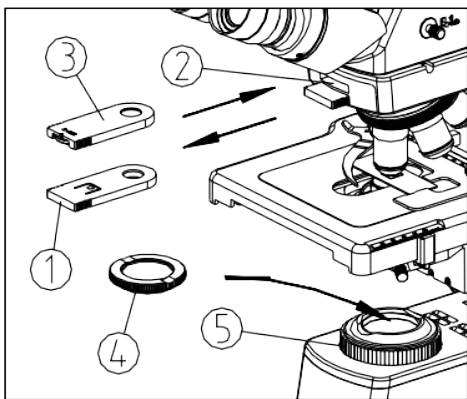

Fig. 27

Using the Simple Polarizer – (Fig. 27)

Simple polarizing includes the analyzer ③ and the 360° polarizer ④. (Fig. 27)

INSTALLATION:

Unplug the analyzer dust cap ① from the top slot ② in the arm and insert the analyzer face up as shown.

Place the polarizer in the illuminator well ⑤ on top of the field iris diaphragm as shown.

Rotation of the polarizer will change the orthogonal status of polarization.

NOTE: When the image is darkest as you view through the eyepieces, polarization has been achieved.

ADJUSTMENT & OPERATION *(continued)*

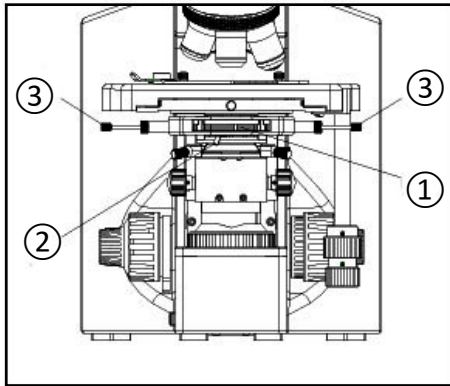

Fig. 28

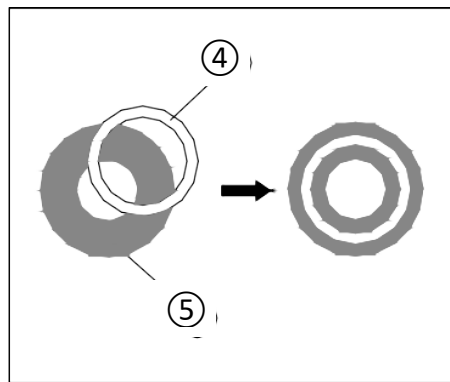

Fig. 29

IMPORTANT: Proper phase annulus halo centration is essential for quality phase contrast observation.

If a double halo appears, center the brightest halo to the objective phase ring.

Assembling & Operating

Turret Phase Contrast Condenser– (Fig. 28)

The phase contrast condenser contains positions for magnification-specific ring diaphragms and a brightfield “BF” position on the condenser turret (1). In phase contrast observation, the ring diaphragm magnification shown on the condenser turret (1) should match with the magnification of the phase contrast objective.

For brightfield observation, turn the condenser turret (1) to “BF” position. Detents provide “click stops” when the condenser turret (1) has reached a position for observation (a diaphragm or BF position is centered in the optical path (see Fig. 28).

Centering the Phase Annulus – (Fig. 28 & 29)

- (1) Rotate the 10X phase contrast objective into the light path, then rotate the condenser turret (1) to the 10X position.
- (2) Turn the aperture diaphragm lever (2) all the way to the left (most open). **Always keep the aperture diaphragm fully open for phase contrast observation.**
- (3) Place a specimen on the stage and focus.
- (4) Remove one observation eyepiece and place a centering telescope (CT) into the empty eye tube. Ensure that the CT is in the eye tube without a diopter adjustment.
- (5) Loosen the lock screw of the centering telescope, slide the telescope tube up and down until the image of the phase annulus (4) (halo) and phase ring (5) are clear and in focus. Lock the screw to hold the position. (See Fig. 28 & 29)
- (6) If the phase annulus and phase ring are not centered and perfectly overlaid, use the phase contrast ring adjusting lever (3) to center the annulus (the phase ring (5) cannot move). While observing through the centering telescope, press the phase contrast ring adjusting levers into the condenser, then twist each left or right to align and center the phase annulus halo (4) over the phase ring (5). A properly aligned and centered phase annulus halo (4) will appear as in the right side of Fig. 29.
- (7) Remove the CT from the eye tube, and reinsert the eyepiece to observe the phase contrast effect.
- (8) Adjust the other phase contrast annuli (4) for the other phase contrast objective magnifications according to the steps above.

ADJUSTMENT & OPERATION *(continued)*

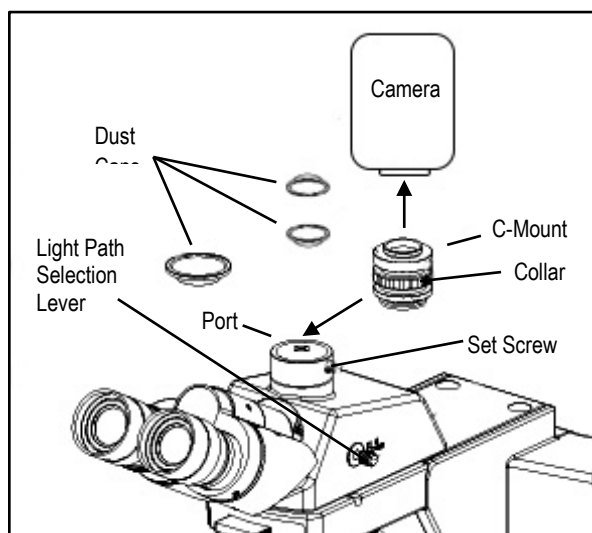

Fig. 30

Installing a Camera Adapter & Camera – (Fig. 30)

Install the C-mount adapter onto the camera before mounting it to the trinocular head port by first removing any dust cap(s) from the C-mount adapter and camera, then gently screw the threaded top of the C-mount onto the bottom of the camera.

Remove the dust cap on the trinocular head port.

Using the included Hex wrench, loosen the set screw on the trinocular head camera port until it is flush with the inside, then gently mount the C-mount/camera into the port and tighten the set screw.

Observe the image through the eyepieces by pushing the light path selection lever all the way in, then bring the image into focus.

Pull the light path selection lever all the way out, and while observing the image on a monitor, adjust the focus of the image via the C-mount collar until it matches the focus as seen through the eyepieces.

NOTE: *Be sure to keep all dust caps in a safe place for future use when a camera is not mounted to the microscope.*

TROUBLESHOOTING

Under certain conditions, performance of this unit may be adversely affected by factors other than defects. If a problem occurs, please review the following list and take remedial action as needed. If you cannot solve the problem after checking the entire list, please contact your local dealer for assistance.

OPTICAL

Problem	Cause	Corrective Measure
The field of view is dark, but the bulb is bright	Field diaphragm is not open enough Condenser is too low Condenser is not centered Light path selection lever is in the trinocular position	Open the field diaphragm more Adjust the condenser height Center the condenser Push the light path selection level into the binocular position
Darkness at the periphery or uneven brightness of view field	Revolving nosepiece not in click stop position	Revolve the nosepiece to click stop position by swinging the objective correctly into the optical path
Dirt or dust on the view field	Dirt or dust on the lens - eyepiece, condenser, objective, collector lens or specimen	Clean the lens
Poor image quality	No cover glass attached to the slide Cover glass is too thick or thin Slide maybe upside down Immersion oil is on a dry objective (especially the 40xR) No immersion oil used with 100xR objective Air bubbles in immersion oil Condenser aperture is closed or open too much Condenser is positioned too low	Attach a 0.17mm cover glass Use a cover glass of the appropriate thickness (0.17mm) Turn slide over so the cover glass faces up Check the objectives, clean if necessary Use immersion oil Remove bubbles Open or close properly Position the condenser slightly lower than the upper limit

IMAGE PROBLEMS

Problem	Cause	Corrective Measures
Image moves while focusing	Specimen rises from stage surface Revolving nosepiece is not in the click-stop position	Secure the specimen in the slide holder Revolve the nosepiece to the click-stop position
Image tinged yellow	Lamp intensity is too low Blue filter not used	Adjust the light intensity by rotating the intensity control dial and/or iris diaphragm Use daylight blue filter
Image is too bright	Lamp intensity is too high	Adjust the light intensity by rotating the intensity control dial and/or iris diaphragm
Insufficient brightness	Lamp intensity is too low Aperture diaphragm closed too far Condenser position too low	Adjust the light intensity by rotating the intensity control dial and/or iris diaphragm Open to the proper setting Position the condenser slightly lower than the upper limit

MECHANICAL PROBLEMS

Image will not focus with high power objectives	Slide upside down Cover glass is too thick	Turn the slide over so the cover glass faces up Use a 0.17mm cover glass
High power objective contacts slide when changed from low power objective	Slide upside down Cover glass is too thick Diopter adjustment is not set properly	Turn the slide over so the cover glass faces up Use a 0.17mm cover glass Readjust the diopter settings as outlined in section 4.3

MECHANICAL PROBLEMS *(continued)*

Problem	Cause	Corrective Measures
Lamp does not light when switched on	No electrical power Lamp bulb burnt out Fuse blown out	Check power cord connection Replace bulb Replace fuse
Slippage of focus when using the coarse focusing knob	Tension adjustment is set too low	Increase the tension on the focusing knobs
Fine focus is ineffective	Tension adjustment is set too high	Loosen the tension on the focusing knobs

MAINTENANCE

Please remember to **never** leave the microscope with any of the objectives or eyepieces removed and always protect the microscope with the dust cover when not in use.

SERVICE

ACCU-SCOPE® microscopes are precision instruments which require periodic servicing to keep them performing properly and to compensate for normal wear. A regular schedule of preventative maintenance by qualified personnel is highly recommended. Your authorized ACCU-SCOPE® distributor can arrange for this service. Should unexpected problems be experienced with your instrument, proceed as follows:

1. Contact the ACCU-SCOPE® distributor from whom you purchased the microscope. Some problems can be resolved simply over the telephone.
2. If it is determined that the microscope should be returned to your ACCU-SCOPE® distributor or to ACCU-SCOPE® for warranty repair, pack the instrument in its original Styrofoam shipping carton. If you no longer have this carton, pack the microscope in a crush-resistant carton with a minimum of three inches of a shock absorbing material surrounding it to prevent in-transit damage. The microscope should be wrapped in a plastic bag to prevent Styrofoam dust from damaging the microscope. Always ship the microscope in an upright position; **NEVER SHIP A MICROSCOPE ON ITS SIDE**. The microscope or component should be shipped prepaid and insured.

LIMITED MICROSCOPE WARRANTY

This microscope and its electronic components are warranted to be free from defects in material and workmanship for a period of five years from the date of invoice to the original (end user) purchaser. The LED lamp is warranted for a period of one year from the date of invoice to the original (end user) purchaser. This warranty does not cover damage caused in-transit, misuse, neglect, abuse or damage resulting from improper servicing or modification by other than ACCU-SCOPE approved service personnel. This warranty does not cover any routine maintenance work or any other work, which is reasonably expected to be performed by the purchaser. Normal wear is excluded from this warranty. No responsibility is assumed for unsatisfactory operating performance due to environmental conditions such as humidity, dust, corrosive chemicals, deposition of oil or other foreign matter, spillage or other conditions beyond the control of ACCU-SCOPE INC. This warranty expressly excludes any liability by ACCU-SCOPE INC. for consequential loss or damage on any grounds, such as (but not limited to) the non-availability to the End User of the product(s) under warranty or the need to repair work processes. Should any defect in material, workmanship or electronic component occur under this warranty contact your ACCU-SCOPE distributor or ACCU-SCOPE at (631) 864-1000. This warranty is limited to the continental United States of America. All items returned for warranty repair must be sent freight prepaid and insured to ACCU-SCOPE INC., 73 Mall Drive, Commack, NY 11725 – USA. All warranty repairs will be returned freight prepaid to any destination within the continental United States of America, for all foreign warranty repairs return freight charges are the responsibility of the individual/company who returned the merchandise for repair.

ACCU-SCOPE is a registered trademark of ACCU-SCOPE INC., Commack, NY 11725

v071423